

Pressure Gage Instruments 4-1/2 in. (114 mm) Dial Installation and Operation Instructions

Models: OPLC, OPLFC, OPLBP, OPLFG, 45APE and 45APEF

Please read the following instructions before installing. A visual inspection of this product for damage during shipping is recommended before mounting. It is your responsibility to have a qualified person install the unit.



Before Beginning Installation of this Product:

- 1.) Disconnect all electrical power to the machine.
- 2.) Make sure the machine cannot operate during installation.
- 3.) Follow all safety warnings of the machine manufacturer.
- 4.) Read and follow all installation instructions.

OPLC and OPLFC gage instruments have high and low limit contacts to monitor, alarm or shut down. The OPLC has a flanged case. A method to override the low limit contact for start-up is provided on OPLC models. See Operation Test Instructions. OPLFC can be direct or panel mounted.

OPLFG gage indication-only pressure instrument is similar to OPLFC models, without switch (limit) contacts.

OPLBP is a version of the OPLC featuring pilot duty limit switches connected to an internal latching control relay for on/off control directly or through a motor starter.

-OS and -ES options include oil sealed and environment sealed case for corrosive environment, feature a panel mount case or screw directly into the process.

45APE and 45APEF are versions of the OPLC Series featuring 2 snap-acting SPDT switches instead of the pointer type contacts. These units do not include low contact lockout.

Installation Precautions:

- Do NOT exceed rated pressure range.
- Dope or use teflon tape on connection threads.
- Do not block the inlet orifice.
- For direct mount into the process, a vertical or ninety degree mounting is recommended.
- Use wrench on shank to tighten or loosen connection.
- Do not twist case when installing, this will damage internal components and will void the warranty.
- Do not overtighten.
- Use shock mounts as necessary to prevent excessive vibration.
- If liquid in the system freezes, it will expand and will damage the tube.
- For 45APE Series - Low setpoint should be limited to the lower 1/2 scale and upper setpoint should be limited to the upper 1/2 scale.

Specifications

Dial: White on black, dual scale, psi/kPa standard, 4-1/2 in. (114 mm) diameter

Case: Die cast aluminum, surface or panel mount

Process Connection:

1/4 NPTM to 1000 psi; 1/2 NPTM 1500-10,000 psi.

Sensing Element: Bronze or 316 stainless steel bourdon tube

Snap-Acting Switches: See wiring information (45APE/45APEF)

Overrange: Do not exceed 10% FS above full range

Pressure Relief Disc: Back of case

Dry Relay Contact: OPLBP, 10 A@ 120 VAC

Wire Connections (Surface Mount): 1/2 NPTF conduit entry with terminal block

Wire Connections (Panel Mount):

Wire leads, 18 AWG (1.0 mm²) x 9 in. (229 mm) long

Wire Connections (-ES, -OS): 1/2 NPTM conduit and wire leads,

OPLFC Series: 18 AWG (1.0 mm²) x 33 in. (838 mm) long

Switch Point Accuracy: ± 1.5% (45APE/45APEF)

Switch Reset Deadband: Approximately 10% FS (45APE/45APEF)

Gage Accuracy:

All models between switch points:
± 2% for first and last quarters of scale; middle half of scale is ± 1 %

Based on testing performed with switch point at mid scale which represents worst case.

45APE/45APEF Accuracy Outside Switch Points	
Range	Accuracy Above or Below Trip Point
<100	10
100-300	4
400-1500	2
2000	12
3000-5000	8

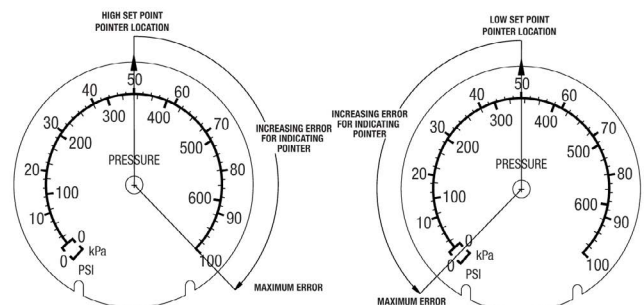

Dimensions and Mounting Diagrams

OPLC Series Wall Mount

Flanged case design intended for wall mount, it can also be direct mounted. Shown with shock mounts and pulsation dampener.

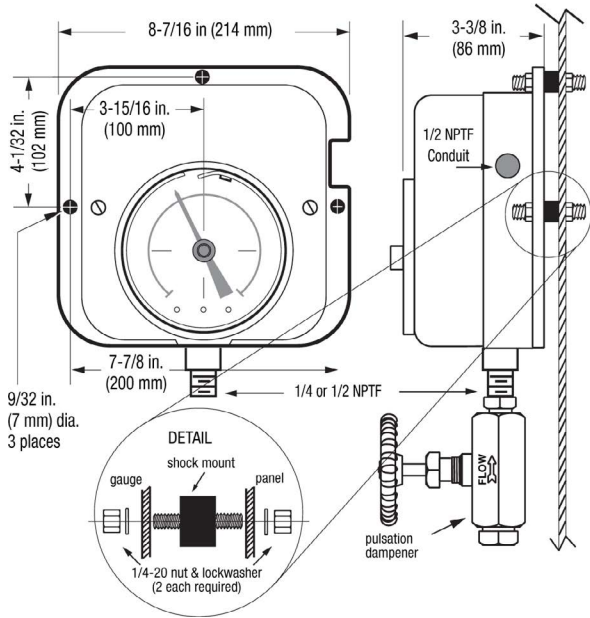

45APE Series Wall Mount

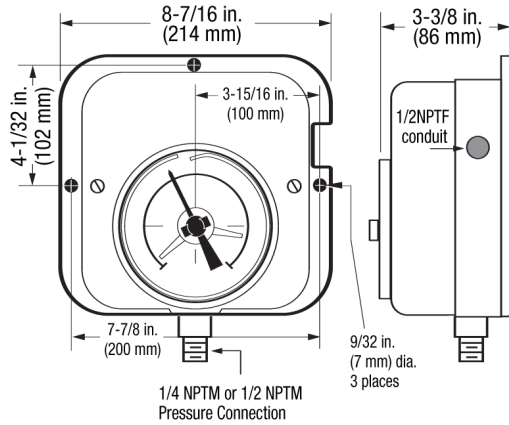

45APEF Series Flush Mount

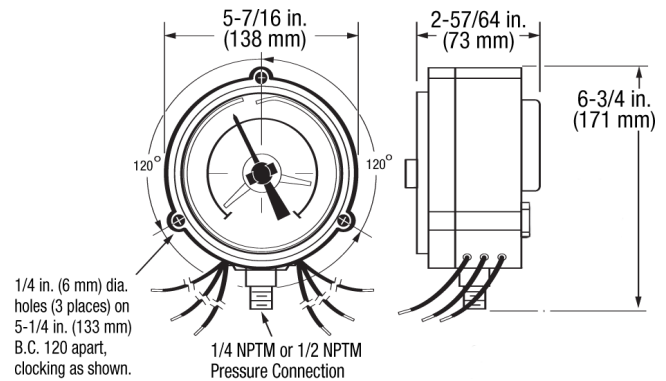

OPLFC Series Flush Mount

Round case design to be mounted in a panel from 1/32 in. (1 mm) to 1/8 in. (3 mm) thick. It can also be direct mounted.

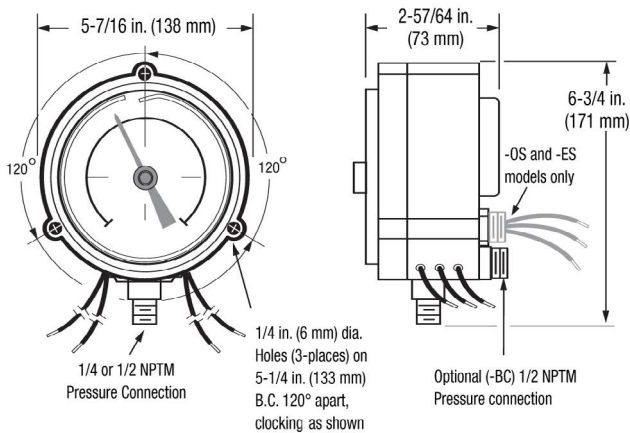

Options -OS and -ES Flush Mount

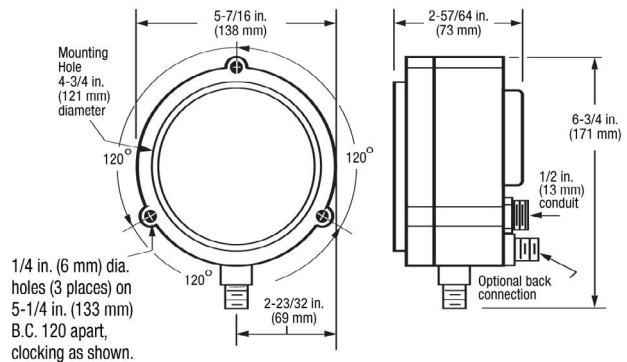

Explosion-proof Case Mount

Explosion-proof case can be mounted from face or rear.

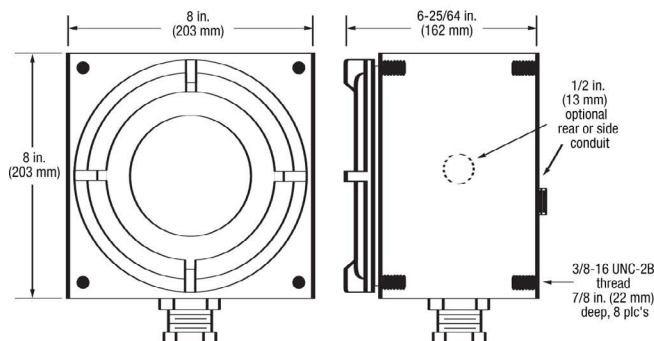

Flush mount/Wall mount

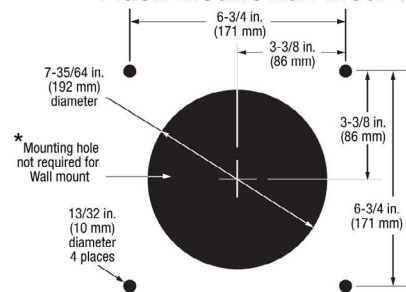

Wiring Information



Before Beginning Wiring of this Product:

- 1.) Perform the wiring operation with the power source OFF.
- 2.) Secure the area to be non-hazardous.
- 3.) Make sure the voltage and current requirements are within the contact ratings.

- Determine voltage and polarity for the application.
- Use the appropriate wire size.
- All connections should be made using a spade (forked) or ring terminals.
- For pigtail connections use wire nuts.
- Conduit is recommended to protect wires from damage.

45APE and 45APEF

Contact Rating:

2 SPDT Snap-switches (one for high and low pressure),
2 A inductive, 250 VAC each switch.

NOTE: Indication pointer shown at rest (shelf) position.

Low setpoint should be limited to the lower 1/2 scale and upper setpoint should be limited to the upper 1/2 scale.

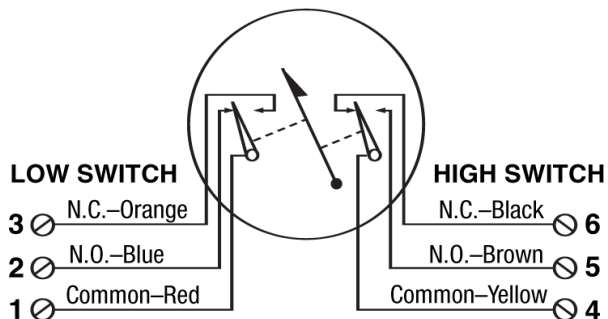

OPLBP

Contact Rating:

SPDT, Dry Relay Contacts 10 A, 125 VAC.

NOTE: Indication pointer shown at rest (shelf) position.

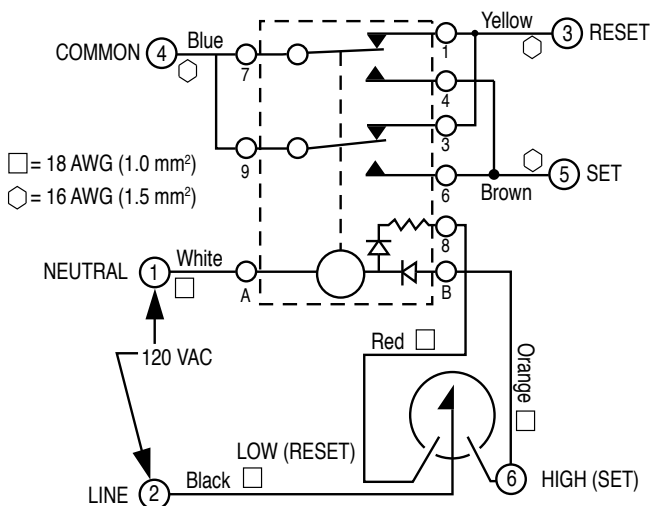

OPLC and OPLFC

Contact Rating:

1 SPDT, Center Off; 2 A, 30 VDC / 0.1 A, 125 VAC pilot duty.

NOTE: Indication pointer shown at rest (shelf) position.



Making Adjustments

OPL Series Limit Contact Adjustments

Facing the dial, left side knob is the Low limit contact and the High limit contact is located to the right. To set the limit contacts simply turn the fingertip type knob to the desired point on the scale.

OPL Series Indicating Point Adjustments

To reset to zero or to a known value do as follows:

1. Turn off electrical power. Remove the snap ring and very carefully remove the lens and contact assembly (or open hinged cover).
2. Hold the pointer hub with thumb and forefinger then turn screw to desired point. See DETAIL A.
3. Replace lens and contact assembly and snap ring (or close hinged cover), and turn on the power.

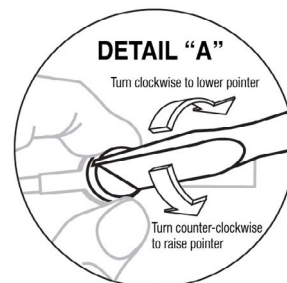

45APE Series Trip Point Adjustments

The 45APE Series features a stacked limit indicator adjustments knob. The bottom half knob adjusts the Low limit indicator, the top half is to adjust the High limit indicator. To set the limit contacts simply turn the fingertip type knob to the desired point on the scale.

Making Adjustments (continued)

45APE Series Pointer Adjustments (if necessary)

Verify that pointer is at zero with zero pressure.

To reset to zero or to a known value proceed as follows:

1. Turn off electrical power. Remove the snap ring and very carefully remove the lens and contact assembly (or open hinged cover).
2. Hold the Switch Operator and the pointer hub with thumb and forefinger, then turn the Pointer Adjustment screw to the desired point. See DETAIL B.
3. If the Switch Operator needs adjustment, hold the Switch Operator and the pointer hub with thumb and forefingers as show on DETAIL C, and turn the adjustment screw until the Switch Operator aligns with the indicating pointer.
4. Replace the lens and contact assembly and the snap ring (or close hinged cover). Turn the power back on.

CAUTION: Don't rotate set point arms past stop pins in circle.

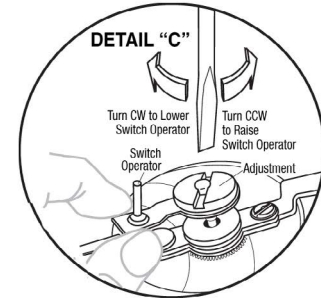
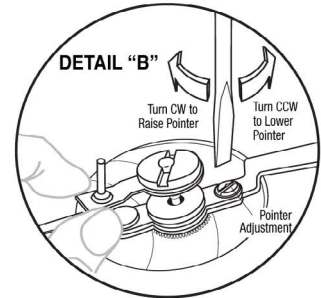

Operation Test Instructions

OPLC, OPLFC and OPLBP

1. Perform operation test after the unit is installed and wired appropriately.
2. When pressure is applied to the instrument, the pointer will travel in a clockwise direction. Adjust the limit contacts to the desired settings.
3. To start, place the toggle switch in the START position or otherwise override low contact.
4. After the indication pointer rises above the low limit contact, return the toggle switch or override device to the RUN position.
5. To test the limit contacts, turn the limit contact to be tested until it touches the pointer. That will trip the control circuit.
6. Reset the shutdown or alarm circuit device and repeat above sequence for each contact/trip point.
7. For the OPLC and OPLBP models, to maintain the NEMA 3R rating, torque the two cover screws down from 27 to 35 in. lbs after installation and testing are complete.

45APE and 45APEF

1. Perform operation test after the unit is installed and wired appropriately.
2. When pressure is applied to the instrument, the pointer will travel in a clockwise direction. Adjust the limit contacts to the desired settings.
3. To test the switches, turn the trip point indicator until it is aligned with the switch gage pointer. This is the approximate trip point. Continue to rotate until the snap switch operates.
4. Reset the shutdown or alarm circuit device.

In order to consistently bring you the highest quality, full-featured products, we reserve the right to change our specifications and designs at any time. FW MURPHY product names and the FW MURPHY logo are proprietary trademarks. This document, including textual matter and illustrations, is copyright protected with all rights reserved. (c) 2023 FW MURPHY. A copy of our typical warranty may be viewed or printed by going to www.fwmurphy.com/warranty.

FW MURPHY PRODUCTION CONTROLS
SALES, SERVICES & ACCOUNTING
4646 S. HARVARD AVE.
TULSA, OK 74135

MANUFACTURING
2151 RANDON DYER ROAD
ROSENBERG, TX 77471

5757 FARINON DRIVE
SAN ANTONIO, TX 78249

DOMESTIC SALES & SUPPORT
FW MURPHY PRODUCTS
PHONE: 918 957 1000
EMAIL: INFO@FWMURPHY.COM
WWW.FWMURPHY.COM

FW MURPHY CONTROL SYSTEMS & SERVICES
PHONE: 281 633 4500
EMAIL: CSS-SOLUTIONS@FWMURPHY.COM

INTERNATIONAL SALES & SUPPORT
CHINA
PHONE: +86 571 8788 6060
EMAIL: INTERNATIONAL@FWMURPHY.COM

LATIN AMERICA & CARIBBEAN
PHONE: +1 918 770 8775
EMAIL: INTERNATIONAL@FWMURPHY.COM



FM 668576 (San Antonio, TX - USA)
FM 668933 (Rosenberg, TX - USA)